

- Allows simultaneous sampling across multiple AlazarTech waveform digitizers
- Four coherent clock outputs
- Four synchronous trigger outputs
- Internal clocking up to 1 GHz
- External clocking up to 2 GHz
- Trigger holdoff function for safe synchronous arming of multiple boards
- Software library for user programmability
- USB 2.0 controlled
- Support for Windows® & Linux®



Product	Interface	Operating System	Max. Number of Digitizers	Max. Internal Clock Frequency	Max. External Clock Frequency
ATS Sync 4X1G	USB 2.0	64-bit Windows & 64-bit Linux	4	1 GHz	2 GHz

### Overview

The AlazarTech ATS® Sync 4X1G is a device that allows simultaneous sampling across multiple independent AlazarTech waveform digitizers. This is achieved by providing common clock and trigger signals to each digitizer.

While it is possible to supply copies of clock and trigger signals using passive signal splitters, that scheme does not prevent the triggering of some digitizers while the rest of the digitizers are still being armed. Sync 4X1G solves this problem by allowing users to disable triggering during the digitizer arming process and enable it only after all digitizers are armed.

Sync 4X1G is supplied with a graphical user interface called SyncApp for Windows and a command-line application for Linux that allow users to control the trigger and clock.

Coupled with the provided AlazarDSO® oscilloscope software for Windows or AlazarFrontPanel for Linux, this allows users to get started immediately without having to write any software.

Users who need to integrate their digitizers and Sync 4X1G in their own program can use the provided drivers, library, and code sample with the ATS-SDK software development kit for Windows or Linux.

### USB 2.0 Computer Interface

ATS Sync 4X1G interfaces to the host computer using a provided USB type A to type B cable.

The USB type A connector is used to connect to the host computer. The USB type B connector is used to connect to the Sync 4X1G.

### Compatible Waveform Digitizers

All AlazarTech PCI Express and Thunderbolt 3 waveform digitizers are compatible with ATS Sync 4X1G. AlazarTech PCI bus waveform digitizers are not supported.

### How ATS Sync 4X1G Works

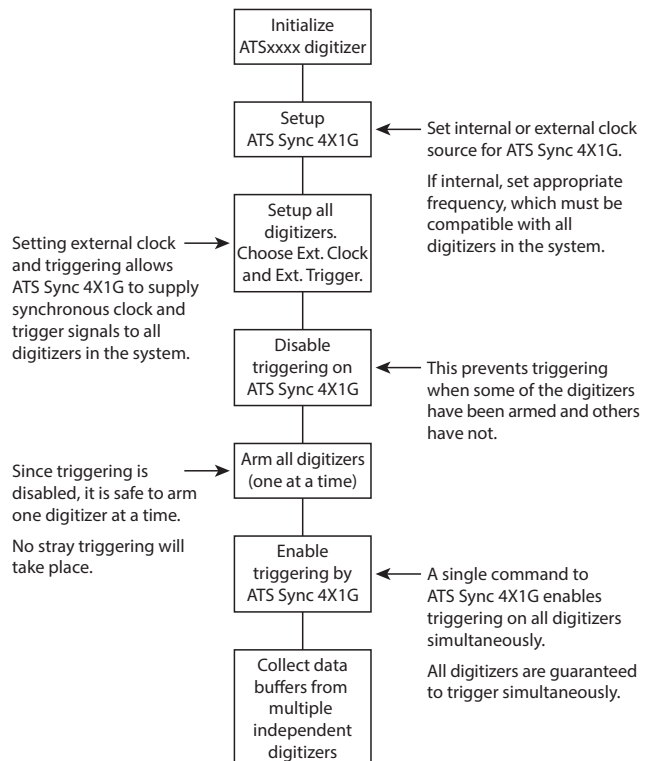

ATS Sync 4X1G Connection Diagram

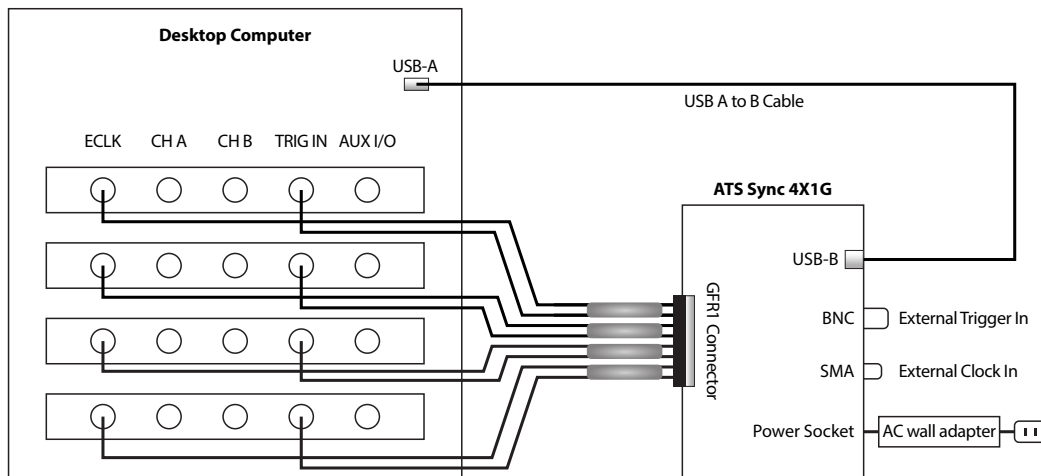

### ATS Sync 4X1G to Digitizer Interface

Sync 4X1G interfaces to AlazarTech digitizer cards using a proprietary high-frequency cable. The provided cable terminates in a ganged micro-miniature RF connector, which is used to connect to the Sync 4X1G.



The other end of the cable terminates in male SMA and BNC connectors, which are used to connect to the digitizer External Clock and External Trigger respectively.

Depending on the model of AlazarTech digitizer used with Sync 4X1G, BNC-to-SMA cable adapters may be necessary and must be sourced by the user.

One cable is included with the purchase of Sync 4X1G. Additional cables can be purchased (order number SYNC-4X1-CBL).

### Clock Source

The ATS Sync 4X1G allows the user to programmatically choose between an external clock or an internally generated clock. The selected clock is then distributed to all four outputs.

#### External Clock

The user can supply a single-ended clock signal through ECLK IN connector. This signal can have variable frequency, such as a k-clock in OCT applications.

The clocking requirements of the AlazarTech digitizers being used must be satisfied. Refer to your digitizer specifications for the External Clock frequency requirements.

#### Internal Clock

The Sync 4X1G has an on-board low-jitter VCO that generates the required clock. The On-board low-jitter VCO uses a 10 MHz TCXO as a reference

clock and a high-performance VCO and PLL chipset to generate a low-jitter clock.

The maximum frequency for internal clock is 1 GHz. Lower frequencies must satisfy the following formula:

$$output\_clock = \frac{vco\_clock}{vco\_divider * output\_divider}$$

Conditions:

- $1800\text{ MHz} \leq vco\_clock \leq 2200\text{ MHz}$
- $vco\_clock$  must be a multiple of 10 MHz
- $2 \leq vco\_divider \leq 6$
- $1 \leq output\_divider \leq 32$

Users must use the above formula to calculate the appropriate internal clock frequency.

### Triggering

The ATS Sync 4X1G supports digital (TTL) triggering. Four exact copies of the trigger signal supplied through the TRIG IN connector are output to the digitizer boards.

Sync 4X1G also supports Trigger Enable and Trigger Disable. This allows the user to hold off triggering until all digitizers are armed.

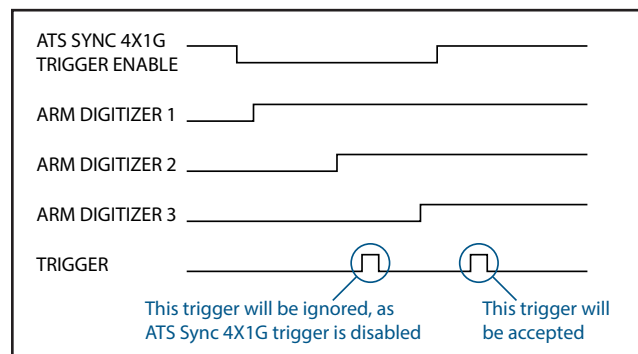

### Use with digitizers operating at different sample rates

It is also possible to use ATS Sync 4X1G with AlazarTech waveform digitizers operating at different sampling rates. These may be multiple digitizers of the same type, each setup with a different sample rate, or multiple digitizers of different types, e.g. ATS9371 and ATS9352.

In this case, Clock outputs of Sync 4X1G will not be connected to the digitizers. Each digitizer's clock source and sampling speed must be set as if it is an independent board. Trigger outputs of Sync 4X1G will be connected to the various digitizers to ensure that none of them accept a trigger before all of them are armed.

Note that only the trigger will be synchronized between digitizers. Sampling clocks will not be coherent.

### Recommended AC-DC Power Supply

ATS Sync 4X1G is a self-powered USB 2.0 device; it does not draw any power from the USB cable. Users must supply the necessary power to the Sync 4X1G for it to operate.

The power supply must be ordered separately (order# SYNC-X1G-PWR). Customers may opt to order the Pihong USA PSC15A-050 or the CUI Inc. SWI18-5-N-P5 power supply directly from their preferred electronic component supplier such as Digi-Key or Mouser.

Please note that power supplies purchased from AlazarTech will come with a type A (NEMA 1-15P) plug. Customers who require a different plug type should refer to the section "AC Wall Adapter (sold separately)" on page 5 and source a suitable power supply from their preferred electronic component supplier.

The power supplies specified above have undergone testing at our factory and are recommended power supplies for the Sync 4X1G.

### Performance Verification

Every ATS Sync 4X1G is tested at factory to ensure that it performs within specification.

### RoHS Compliance

ATS Sync 4X1G is fully RoHS compliant, as defined by Directive 2015/863/EU (RoHS 3) of the European Parliament and of the Council of 31 March 2015 on the restriction of the use of certain hazardous substances in electrical and electronic equipment.

All manufacturing is done using RoHS-compliant components and lead-free soldering.

### REACH Compliance

AlazarTech verifies its supply chain against the latest REACH requirements.

A compliance statement is usually available within 6 months of release of the European Chemicals Agency (ECHA) updated substance of very high concern (SVHC), Authorizations, and Restrictions lists.

### ATS Sync 4X1G Installation Package

Sync 4X1G is supplied with software installation packages for Windows and Linux on USB flash drive. The installation package includes:

- Sync 4X1G driver & library
- SyncApp control application, which allows the user to control the ATS Sync 4X1G's functions.
- Sync 4X1G code sample for use with ATS-SDK for customers who wish to create their own software to control their AlazarTech digitizers.

C++ and Python example code for using Sync 4X1G is included with the Sync 4X1G software installation package. The C++ example program is provided with CMake build files for use under Windows and Linux. Calling the function from other programming languages is the responsibility of the user.

### Support for Windows

Windows support for ATS Sync 4X1G includes Windows 11, Windows 10, Windows Server® 2019, and Windows Server 2016. As Windows Server 2019 and 2016 are seldom used by our customers, they are expected to work but are not regularly tested with each software release. If there are issues related to Windows Server 2016 or 2019, tech support may not be as rapid as for other operating systems.

Only 64-bit Windows operating systems are supported.

### Linux Support

AlazarTech offers Dynamic Kernel Module Support (DKMS) drivers for the following Linux distributions: Ubuntu, Debian, and RHEL® for AlazarTech digitizers.

AlazarTech DKMS drivers may work for other Linux distributions but they have not been tested and technical support may be limited.

Users will be able to download the DKMS driver and associated library for their specific distribution from the *Linux Resources* section on their digitizer's product web page.

Only 64-bit Linux operating systems are supported.

A GUI application called AlazarFrontPanel that allows simple data acquisition and display is also provided.

ATS-SDK includes source code example programs for Linux that demonstrate how to acquire data programmatically using a C compiler. Note that example programs are only provided for Python and C++.



# ATS SYNC 4X1G

## Clock & Trigger Synchronizer

### Extended Warranty

The purchase of an ATS Sync 4X1G includes a standard one (1) year parts and labor warranty. AlazarTech hardware parts and labor warranty should be maintained to ensure uninterrupted access to technical support and warranty repair services.

Customers may extend their warranty by ordering an Extended Warranty (order number SYNC-4X-061). This must be purchased before expiration of the standard warranty (or before expiration of an Extended Warranty).

If the warranty lapses, renewal at a later date will incur reinstatement fees for the forward service period and any applicable warranty extension to cover the lapsed period, as well as a 6-month waiting period for repair claims. Furthermore, warranty must be extended at least 6 months past the current date. The reinstatement fee is 15% of the cost of warranty extension.

Users can purchase up to 4 (four) additional years of warranty extensions for a maximum total of 5 years of warranty.

Get your warranty end date by registering your product at: [www.alazartech.com/en/my-account/my-products/](http://www.alazartech.com/en/my-account/my-products/).

### ORDERING INFORMATION

ATS Sync 4X1G	Please refer to your digitizer's price list for order number	
ATS Sync 4X1G: GRF1-SMA/BNC		SYNC-4X1-CBL
Sync 4X1G: One Year Extended Warranty		SYNC-4X1-061
ATS Sync xX1G: DC Power Supply		SYNC-X1G-PWR
ATS-SDK purchased with a digitizer board or ATS-GPU: License + 1 Year Subscription (Supports C/C++, Python, MATLAB, and LabVIEW)		ATS-SDK
ATS-SDK purchased separately: License + 1 Year Subscription + 5 hours of technical support (Supports C/C++, Python, MATLAB, and LabVIEW)		ATS-SDK-WOD
5 Hours of technical support		SUPPORT-HR5

† AlazarDSO, AlazarTech, and AlazarTech ATS are registered trademarks of Alazar Technologies Inc. MATLAB is a trademark and/or registered trademark of The MathWorks, Inc. LabVIEW is a trademark and/or registered trademark of National Instruments. Windows and Windows Server are trademarks and/or registered trademarks of Microsoft Corporation in the U.S. and/or other countries. Linux is a registered trademark of Linus Torvalds. RHEL is a registered trademark of Red Hat, Inc. in the United States and other countries. All other trademarks are the property of their respective owners.



# ATS SYNC 4XIG Clock & Trigger Synchronizer

## System Requirements

Personal computer with at least one free USB 2.0+ port, 16 GB RAM, 100 MB of free hard disk space.

## Power Requirements

+5 V 1 A, typical

## AC Wall Adapter (sold separately)

Output	+5 Vdc, 3 Amps (15 W)
Output connector type	Barrel, Male plug
Inner pin	2.1 mm diameter
Outer barrel	5.5 mm diameter
Pin length	9.5 mm
Polarity	Center pin POSITIVE
Tested AC wall adapters	Phihong USA PSC15A-050 CUI Inc. SWI18-5-N-P5

## Physical

Size	Metal chassis measures 5.1 x 2.6 x 1.6 inches (excluding any protruding connectors).
Weight	166 g

## I/O Connectors

TRIG IN	BNC female connector
ECLK IN	SMA female connector
Outputs	Ganged micro-miniature RF connector for connecting provided cable terminating in 4x BNC (TRIG OUT 1-to-4) and 4x SMA (ECLK OUT 1-to-4)

## Environmental

Operating temperature	0 to 55 degrees Celsius
Storage temperature	-20 to 70 degrees Celsius
Relative humidity	5 to 95%, non-condensing

## Internal Clock Generator

Reference clock	10 MHz
Maximum frequency for Internal Clock	1 GHz
Frequency output	$output\_clock = \frac{vco\_clock}{vco\_divider * output\_divider}$
Conditions:	<ul style="list-style-type: none"> <li>◦ 1800 MHz ≤ vco_clock ≤ 2200 MHz</li> <li>◦ vco_clock must be a multiple of 10 MHz</li> <li>◦ 2 ≤ vco_divider ≤ 6</li> <li>◦ 1 ≤ output_divider ≤ 32</li> </ul>

## ECLK (External Clock) Input

Signal Level	500 mV <sub>p-p</sub> to 2 V <sub>p-p</sub>
Input impedance	50 Ω
Input coupling	AC
Maximum frequency for Fast External Clock	2 GHz
Minimum frequency for Fast External Clock	1 MHz

## Clock Output

Source	External clock input or internal clock generator
Signal Level	400 mV <sub>p-p</sub> ~ 800 mV <sub>p-p</sub>
Output impedance	50 Ω
Output coupling	AC
Number of outputs	4 common (same frequency and phase)
Maximum frequency	2 GHz for external clock 1 GHz for internal clock
Minimum frequency	1 MHz. Note: Minimum clock frequency of your digitizer may be higher.

## TRIG IN (External Trigger) Input

Input type	3.3 V TTL
Input coupling	DC only
Analog input impedance	2 kΩ
Max. frequency (-3 dB)	DC - 10 MHz
TTL min. pulse width	32 ADC sampling clocks
TTL min. pulse amplitude	2 Volts
TTL absolute max. input	-0.7 V to +5.5 V

## Trigger Output

Signal type	3.3 V TTL
Number of outputs	4 common (same frequency and phase)
Input coupling	DC only
Max. frequency (-3 dB)	10 MHz

## Materials Supplied

ATS Sync 4XIG  
1 x Cable GRF1-SMA/BNC, order#: SYNC-4X1-CBL  
1 x Cable USB 2.0, Type-A-Male to Type-B-Male

## Required Accessories

ATS Sync 4X1G AC Wall Adapter, order#: SYNC-X1G-PWR

## Certification and Compliances

RoHS 3 (Directive 2015/863/EU) Compliance  
REACH Compliance  
CE Marking — EC Conformity  
FCC Part 15 Class A / ICES-003 Class A Compliance

*All specifications are subject to change without notice*

**Manufactured By:**  
**Alazar Technologies Inc.**  
 6600 TRANS-CANADA HIGHWAY, SUITE 310  
 POINTE-CLAIRE, QC, CANADA H9R 4S2  
 TOLL FREE: 1-877-7-ALAZAR  
 TEL: (514) 426-4899 FAX: (514) 426-2723  
 E-MAIL: sales@alazartech.com



### DATASHEET REVISION HISTORY

#### Changes from version 1.0A (Dec 2023) to version 1.0B

#### Section, Page

Added detail on example code: C++ and Python	ATS Sync 4X1G Installation Package, pg. 3
Updated digitizer driver location	Linux Support, pg. 3
Added missing paragraph in warranty reinstatement policy	Extended Warranty, pg. 4
Removed section; classification is inherited from digitizer	Export Control Classification, pg. 4
Updated order information	Ordering Information, pg. 4

#### Changes from version 1.0 (Aug 2023) to version 1.0A

#### Section, Page

Updated/added product photos	Global change
Modified to include new warranty reinstatement policy	Extended Warranty, pg. 3