

- 2 channels sampled at 12-bit resolution
- 20 MS/s simultaneous real-time sampling rate on each input
- $\pm 40$  mV to  $\pm 20$  V input range
- Up to 8 million samples of on-board acquisition memory per channel
- AlazarDSO<sup>®</sup> oscilloscope software
- Software Development Kit supports C/C++, C#, Python, MATLAB<sup>®</sup>, LabVIEW<sup>®</sup>
- Support for Windows<sup>®</sup> & Linux<sup>®</sup>



For new designs, please use [ATS9120](#)

Product	Bus	Operating System	Channels	Max. Sample Rate	Bandwidth	Memory Per Channel	Resolution
ATS310	PCI 32 bit 33 MHz	32-bit/64-bit Windows & 64-bit Linux	2	20 MS/s	10 MHz	128K Std. or 8M Optional	12 bits

### Overview

AlazarTech ATS<sup>®</sup>310 is a dual-channel, 12 bit, 20 MS/s waveform digitizer card for PCI bus, capable of storing up to 8 Million samples per channel of acquired data in its on-board memory.

It should be noted that it is not possible for ATS310 acquisition memory to be dual-ported. For applications that require dual-port memory, consider using ATS9120.

For scientific customers who want to record multiple analog inputs simultaneously, ATS310 offers multi-channel data acquisition systems of up to 8 channels.

ATS310 is supplied with AlazarDSO oscilloscope software that lets the user get started immediately without having to write any software.

Users who need to integrate the ATS310 in their own program can purchase a software development kit, ATS-SDK, for C/C++, C#, Python, MATLAB, and LabVIEW for both Windows and Linux operating systems.

All of this advanced functionality is packaged in a low-power, half-length PCI card.

### Not Recommended for New Designs

Motherboards with PCI slots are becoming increasingly difficult to source. Customers should, therefore, consider using the ATS9120 PCIe waveform digitizer, which provides 12-bit, 20 MS/s dual-channel sampling, and dual-port memory, for the same price as ATS310.

Dual-port memory, which allows streaming of very large gapless data across the PCIe bus for storage in fast disk drives, is not available on ATS310.

### Applications

**Ultrasonic & Eddy Current NDT/NDE**

**Motor Winding Testing**

**Radar/RF Signal Recording & Analysis**

**High-Resolution Oscilloscope**

**Lidar**

**Spectroscopy**

**Multi-Channel Transient Recording**

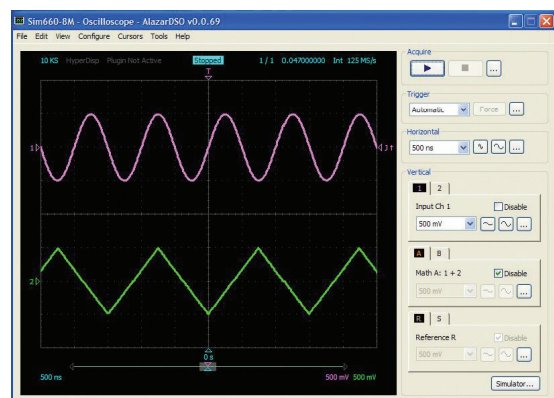

### Analog Input

An ATS310 features two analog input channels with extensive functionality. Each channel has 10 MHz of full power analog input bandwidth. With software-selectable attenuation, you can achieve an input voltage range of  $\pm 40$  mV to  $\pm 20$  V. Attenuating probes (sold separately) can extend the voltage range even higher.

Software-selectable AC or DC coupling further increases the signal measurement capability. Software-selectable 50  $\Omega$  input impedance makes it easy to interface to high-speed RF signals.

### Acquisition System

ATS310 PCI digitizers use a pair of 20 MS/s, 12-bit ADCs to digitize the input signals. The real-time sampling rate ranges from 20 MS/s down to 10 KS/s. The two channels are guaranteed to be simultaneous, as they share the exact same clock.

An acquisition can consist of multiple records, with each record being captured as a result of one trigger event. Minimum number of records is 1 and maximum is 1000. A record may contain both pre-trigger and post-trigger data.

In between the multiple records being captured, the acquisition system is re-armed by the hardware within 8 sampling clock cycles. This mode of capture, sometimes referred to as Multiple Record or Pre-Trigger Multiple Record, is very useful for capturing data in applications with a very rapid trigger rate.

Examples of such applications include ultrasonic testing, NMR spectroscopy, motor testing and lightning test.

### On-Board Acquisition Memory

The standard ATS310 PCI digitizer features 128 Kilo samples of acquisition memory for each channel.

Acquisition memory can optionally be upgraded to provide 8 Million samples per channel of signal storage.

Data is acquired into the onboard memory before being transferred to the host PC memory. This transfer is performed using Direct Memory Access (DMA), which uses scatter-gather bus mastering technology.

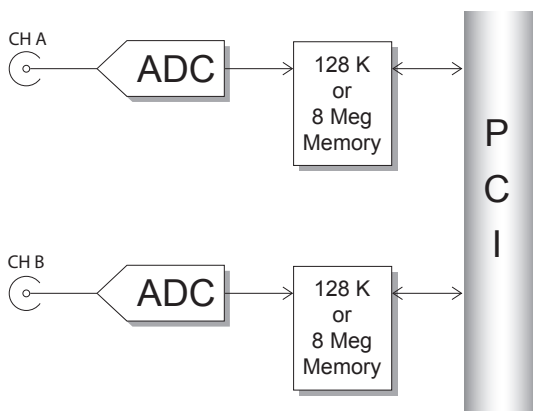

### Triggering

The ATS310 is equipped with sophisticated digital triggering options, such as programmable trigger thresholds and slope on any of the input channels or the External Trigger input.

While most oscilloscopes offer only one trigger engine, ATS310 offers two trigger engines (called Engines X and Y). This allows the user to combine the two engines using a logical OR, AND or XOR operand.

The user can specify the number of records to capture in an acquisition, the length of each record and the amount of pre-trigger data.

A programmable trigger delay can also be set by the user. This is very useful for capturing the signal of interest in a pulse-echo application, such as ultrasound, radar, lidar etc.

### Trigger Time Stamp

A 40-bit time stamp counter comes standard with the ATS310. By default, this counter is initialized to a zero value when an acquisition session is started and increments once for every two samples captured, thus providing a 2-clock timing accuracy. At 20 MS/s sample rate, this counter will not roll over for well over 2 hours.

The value of this counter is latched into trigger memory for each trigger, i.e. once per record, for up to specified number of records.

This allows the user to find out the timing of each trigger in a multiple record acquisition relative to the start of the acquisition.

It is also possible to configure the timestamp counter to reset for the first acquisition only and never again, until a software reset is issued. This feature enables users to obtain precise timing information about multiple acquisitions.

### Multiple-Digitizer Synchronization

ATS310 features a Leader/Follower connector that allows synchronization of multiple digitizers to allow truly synchronous sampling across as many as 8 channels.

A SyncBoard 310 (sold separately) is required to connect the Leader/Follower connectors on multiple digitizers in the system together. Such a system is called a Leader/Follower system.

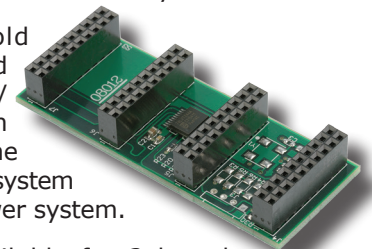

SyncBoard 310 is available for 2 board synchronization or 4 board synchronization.

SyncBoard is a board-level product that features controlled impedance, equal length traces to deliver clock, trigger and initialization signals to each ATS310 in the system.

A Leader/Follower system is guaranteed to sample simultaneously across all channels in that system. Triggering is also guaranteed to be simultaneous across all digitizers in the system.

### Optional External Clock

While the ATS310 features a low-jitter, high-reliability 40 MHz crystal oscillator as the source of the timebase system, there may be occasions when digitizing has to be synchronized to an external clock source.

ATS310 External Clock option provides a BNC input for a TTL compatible external clock signal with a frequency between 20 MHz and 1 MHz.

This clock signal is terminated on the ATS310 printed circuit board using a 50  $\Omega$  resistor. As such, the external clock circuitry must have sufficient drive ( $\pm 66$  mA) to inject the clock signal properly.

The active edge of the external clock is software-selectable between the rising or falling edge.

Users can also set a decimation factor for the external clock. For example, if the user wants to digitize the input signal on every tenth clock edge, this factor can be set to 10. Minimum decimation value is 1 and maximum is 100,000.

### Optional Trigger Output

ATS310 can be optionally equipped with a Trigger Output capability. This option uses the ECLK BNC connector to output a TTL signal synchronous to the ATS310 Trigger signal, allowing users to synchronize their test systems to the ATS310 Trigger.

When combined with the Trigger Delay feature of the ATS310, this option is ideal for ultrasonic and other pulse-echo imaging applications.

Customers who want both External Clock and Trigger Output options on their ATS310 digitizers should contact the factory for arriving at an appropriate cabling solution.

### Calibration

Every ATS310 digitizer is factory calibrated for gain and offset accuracy to NIST- or CNRC-traceable standards. To recalibrate an ATS310, the digitizer must be shipped back to the factory.

### RoHS Compliance

ATS310 units built after June 2007 are fully RoHS compliant, as defined by Directive 2015/863/EU (RoHS 3) of the European Parliament and of the Council of 31 March 2015 on the restriction of the use of certain hazardous substances in electrical and electronic equipment.

All manufacturing is done using RoHS-compliant components and lead-free soldering.

### AlazarDSO Software

ATS310 is supplied with the powerful AlazarDSO software that allows the user to setup the acquisition hardware and capture, display and archive the signals.

The Stream-To-Memory command in AlazarDSO allows users to stream a large dataset to motherboard memory.

AlazarDSO software also includes powerful tools for benchmarking the computer bus and disk drive.

### Software Development Kits

AlazarTech® provides easy-to-use software development kits for customers who want to integrate the ATS310 into their own software.

A Windows and Linux compatible software development kit, called ATS-SDK, includes headers, libraries and source code sample programs written in C/C++, C#, Python, MATLAB, and LabVIEW. These programs can fully control the ATS310 and acquire data in user buffers.

The purchase of an ATS-SDK license includes a subscription that allows users to download ATS-SDK updates from the AlazarTech website for period of 12 months from the date of purchase.

Customers who want to download new releases beyond this 12 month period should purchase extended maintenance (order number ATS-SDK-1YR).

### Support for Windows

Windows support for ATS310 includes Windows 11, Windows 10, Windows Server® 2019, and Windows Server 2016. As Windows Server 2019 and 2016 are seldom used by our customers, they are expected to work but are not regularly tested with each software release. If there are issues related to Windows Server 2016 or 2019, tech support may not be as rapid as for other operating systems.

Microsoft mainstream support ended in 2018 for Windows 8.1 and Windows Server 2012 R2. As such, AlazarTech has ceased development on these operating systems. Current software and driver releases may work with these operating systems but they are not officially supported.

Due to lack of demand and due to the fact that Microsoft no longer supports these operating systems, AlazarTech no longer supports Windows 8, Windows 7, Windows XP, Windows Vista, Windows Server 2012, Windows Server 2008 R2, and Windows Server 2008.



# ATS310

## 20 MS/s 12-Bit PCI Digitizer

### Linux Support

AlazarTech offers Dynamic Kernel Module Support (DKMS) drivers for the following Linux distributions: Ubuntu, Debian, and RHEL®.

AlazarTech DKMS drivers may work for other Linux distributions but they have not been tested and technical support may be limited.

Users can download the DKMS driver for their specific distribution by choosing from the available drivers here:

<ftp://release@ftp.alazartech.com/outgoing/linux>

Only 64-bit Linux operating systems are supported.

A GUI application called AlazarFrontPanel that allows simple data acquisition and display is also provided.

ATS-SDK includes source code example programs for Linux, which demonstrate how to acquire data programmatically using a C compiler.

Based on a minimum annual business commitment, the Linux driver source code license (order number ATS310-LINUX) may be granted to qualified OEM customers for a fee. For release of driver source code, a Non-Disclosure Agreement must be executed between the customer's organization and AlazarTech.

All such source code disclosures are made on an as-is basis with limited support from the factory.

### Technical Support

AlazarTech is known for its world-class technical support. Customers receive free technical support on hardware products that are under warranty.

AlazarTech digitizers come with a standard one (1) year parts and labor warranty. This warranty can be extended for a fee (more information can be found in the next section: Extended Warranty).

If your waveform digitizer is out of warranty, you will not be eligible for free technical support on AlazarTech hardware or software products and you will need to purchase technical support hours (order number SUPPORT-HR5) to obtain assistance.

In addition, any necessary repairs to your out-of-warranty hardware products will carry a minimum bench charge.

### Extended Warranty

The purchase of an ATS310 includes a standard one (1) year parts and labor warranty. Customers may extend their warranty by ordering the appropriate Extended Warranty:

ATS310-061 for ATS310-128K  
ATS310-062 for ATS310-8M

This must be purchased before expiration of the standard warranty (or before expiration of an Extended

Warranty). Extended Warranties can only be purchased while there is a valid warranty in place.

Users can purchase up to 4 (four) additional years of warranty extensions for a maximum total of 5 years of warranty.

Get your warranty end date by registering your product at: [www.alazartech.com/en/my-account/my-products/](http://www.alazartech.com/en/my-account/my-products/).

### Export Control Classification

According to the Export Controls Division of Government of Canada, ATS310 is currently not controlled for export from Canada. Its export control classification is N8, which is equivalent to ECCN EAR99. ATS310 can be shipped freely outside of Canada, with the exception of countries listed on the [Area Control List](#) and [Sanctions List](#). Furthermore, if the end-use of ATS310, in part or in its entirety, is related to the development or deployment of weapons of mass destruction, AlazarTech is obliged to apply for an export permit.

### EC Conformity

ATS310 conforms to the following standards:

Electromagnetic Emissions:

CISPR 22:2006/EN 55022:2006 (Class A):  
Information Technology Equipment (ITE). Radio disturbance characteristics. Limits and method of measurement.

Electromagnetic Immunity:

CISPR 24:1997/EN 55024:1998 (+A1 +A2):  
Information Technology Equipment Immunity characteristics — Limits and methods of measurement.

Safety:

IEC 60950-1:2005: Information technology equipment — Safety — Part 1: General requirements.

IEC 60950-1:2006: Information technology equipment — Safety — Part 1: General requirements.

ATS310 also follows the provisions of the following directives: 2006/95/EC (Low Voltage Equipment); 2004/108/EC (Electromagnetic Compatibility).

### FCC & ICES-003 Compliance

ATS310 has been tested and found to comply with the limits for a Class A digital device, pursuant to part 15, subpart B of the FCC Rules, and the Canadian Interference-Causing Equipment Standard ICES-003:2004.

### System Requirements

Personal computer with at least one free PCI slot, 512 MB RAM, 100 MB of free hard disk space

### Power Requirements

+5 V 1.5 A, typical for ATS310-128K  
1.7 A, typical for ATS310-8M  
+5V voltage level must remain between the range of 4.75 V to 5.20 V at all times after power-on

### Physical

Size Single slot, half length PCI card (4.225 inches x 7.7 inches excluding the connectors protruding from the front panel)  
Weight 500 g

### I/O Connectors

CH A, CH B, EXT, ECLK BNC female connectors

### Environmental

Operating temperature 0 to 55 degrees Celsius  
Storage temperature -20 to 70 degrees Celsius  
Relative humidity 5 to 95%, non-condensing

### Acquisition System

Resolution 12 bits  
Data is returned as MSB-justified 16-bit unsigned integers

Bandwidth (-3 dB)  
DC-coupled, 1 M $\Omega$  DC - 10 MHz  
DC-coupled, 50  $\Omega$  DC - 10 MHz  
AC-coupled, 1 M $\Omega$  10 Hz - 10 MHz  
AC-coupled, 50  $\Omega$  100 kHz - 10 MHz

Bandwidth flatness:  $\pm 1$  dB  
Number of channels 2, simultaneously sampled  
Maximum Sample Rate 20 MS/s single shot  
Minimum Sample Rate 1 KS/s single shot for internal clocking

Full Scale Input ranges  
1 M $\Omega$  input impedance:  $\pm 40$  mV,  $\pm 50$  mV,  $\pm 80$  mV,  $\pm 100$  mV,  $\pm 200$  mV,  $\pm 400$  mV,  $\pm 500$  mV,  $\pm 800$  mV,  $\pm 1$  V,  $\pm 2$  V,  $\pm 4$  V,  $\pm 5$  V,  $\pm 8$  V,  $\pm 10$  V, and  $\pm 20$  V, software-selectable

50  $\Omega$  input impedance:  $\pm 40$  mV,  $\pm 50$  mV,  $\pm 80$  mV,  $\pm 100$  mV,  $\pm 200$  mV,  $\pm 400$  mV,  $\pm 500$  mV,  $\pm 800$  mV,  $\pm 1$  V,  $\pm 2$  V, and  $\pm 4$  V, software-selectable

DC accuracy  $\pm 2\%$  of full scale in all input ranges  
Input coupling AC or DC, software-selectable  
Input impedance 50  $\Omega$  or 1 M $\Omega$   $\pm 1\%$  in parallel with 50 pF  $\pm 10$  pF, software-selectable

Absolute maximum input  
1 M $\Omega$   $\pm 28$  V (DC + peak AC for CH A, CH B and EXT only without external attenuation)  
50  $\Omega$   $\pm 4$  V (DC + peak AC for CH A, CH B and EXT only without external attenuation)

### On-Board Acquisition Memory System

Onboard acq memory 512 Kilobytes for ATS310-128K  
32 Megabytes for ATS310-8M  
Acquisition Memory/ch Up to 128,000 samples per channel for ATS310-128K  
Up to 8 Million samples per channel for ATS310-8M  
Record Length Software-selectable with 16-point resolution. Record length must be a minimum of 256 points. Maximum record length is limited by the acquisition memory per channel.  
Number of Records Software-selectable from a minimum of 1 to a maximum of 1000 or (Acquisition Memory Per Channel / (Record Length+4)), whichever is lower  
Pre-trigger depth 0 to (Record Length-64), software-selectable with 16-point resolution  
Post-trigger depth Record Length - Pre-trigger depth

### Timebase System

Timebase options Internal Clock or External Clock (Optional)  
Internal Sample Rates 20 MS/s, 10 MS/s, 5 MS/s, 2 MS/s, 1 MS/s, 500 KS/s, 200 KS/s, 100 KS/s, 50 KS/s, 20 KS/s, 10 KS/s, 5 KS/s, 2 KS/s, 1 KS/s  
Internal Clock accuracy  $\pm 100$  ppm

### Dynamic Parameters

Typical values measured using a randomly selected ATS310 in  $\pm 1$  V input range, DC coupling and 50  $\Omega$  impedance. Input was provided by a HP8656A signal generator, followed by a 9-pole, 1 MHz band-pass filter. Input frequency was set at 1 MHz and amplitude was 650 mV rms (92% of full scale input).

SNR	60 dB
SINAD	58 dB
THD	-61 dB
SFDR	-62 dB

Note that these dynamic parameters may vary from one unit to another, with input frequency and with the full scale input range selected.

### Optional ECLK (External Clock) Input

Signal Level	TTL levels. Compatible with both 3.3 V and 5 V TTL
Input impedance	50 $\Omega$
Input current requirement	$\pm 66$ mA
Maximum frequency	20 MHz with 50% $\pm 5\%$ duty cycle
Minimum frequency	1 MHz with 50% $\pm 5\%$ duty cycle
Decimation factor	Software-selectable from 1 to 100,000
Sampling Edge	Rising or Falling, software-selectable



# ATS310 20 MS/s 12-Bit PCI Digitizer

## Triggering System

Mode	Edge triggering with hysteresis
Comparator Type	Digital comparators for internal (CH A, CH B) triggering and analog comparators for TRIG IN (External) triggering
Number of Trigger Engines	2
Trigger Engine Combination	Engine J, engine K, J OR K, software-selectable
Trigger Engine Source	CH A, CH B, EXT, Software or None, independently software-selectable for each of the two Trigger Engines
Hysteresis	±5% of full scale input, typical
Trigger sensitivity	±10% of full scale input range. This implies that the trigger system may not trigger reliably if the input has an amplitude less than ±10% of full scale input range selected
Trigger level accuracy	±10%, typical, of full scale input range of the selected trigger source
Bandwidth	10 MHz
Trigger Delay	Software-selectable from 0 to 9,999,999 sampling clock cycles
Trigger Timeout	Software-selectable with a 10 µs resolution. Maximum settable value is 3,600 seconds. Can also be disabled to wait indefinitely for a trigger event

## External Trigger (EXT) Input

Input impedance	1 MΩ ±10% in parallel with 30 pF ±10 pF
Bandwidth (-3 dB)	
DC-coupled	DC - 10 MHz
AC-coupled	10 Hz - 10 MHz
Input range	±5 V or ±1 V, software-selectable
DC accuracy	±10% of full scale input
Absolute maximum input	±28 V (DC + peak AC without external attenuation)
Coupling	AC or DC, software-selectable

## Optional Trigger Output

Connector Used	ECLK Customers who want both External Clock and Trigger Output options on their ATS310 digitizers should contact the factory for arriving at an appropriate cabling solution.
Output Signal	5 Volt TTL
Synchronization	Synchronized to rising edge of sampling clock

## Materials Supplied

- ATS310 PCI Card
- ATS310 Installation Disk (on USB Flash Drive)

## Certification and Compliances

- RoHS 3 (Directive 2015/863/EU) Compliance
- CE Marking — EC Conformity
- FCC Part 15 Class A / ICES-003 Class A Compliance

All specifications are subject to change without notice

## ORDERING INFORMATION

ATS310-128K	ATS310-001
ATS310-8M	ATS310-002
ATS310: 128K to 8 Meg Upgrade	ATS310-003
ATS310: External Clock Upgrade	ATS310-004
ATS310: TTL Trigger Output Upgrade	ATS310-005
SyncBoard 310 2x	ATS310-006
SyncBoard 310 4x	ATS310-007
ATS310-128K: One Year Extended Warranty	ATS310-061
ATS310-8M: One Year Extended Warranty	ATS310-062
ATS-SDK purchased with a digitizer board or ATS-GPU: License + 1 Year Subscription (Supports C/C++, Python, MATLAB, and LabVIEW)	ATS-SDK
ATS-SDK purchased separately: License + 1 Year Subscription + 5 hours of technical support (Supports C/C++, Python, MATLAB, and LabVIEW)	ATS-SDK-WOD
5 Hours of technical support	SUPPORT-HR5

† AlazarDSO, AlazarTech, and AlazarTech ATS are registered trademarks of Alazar Technologies Inc.  
 MATLAB is a trademark and/or registered trademark of The MathWorks, Inc.  
 LabVIEW is a trademark and/or registered trademark of National Instruments.  
 Windows and Windows Server are trademarks and/or registered trademarks of Microsoft Corporation in the U.S. and/or other countries.  
 Linux is a registered trademark of Linus Torvalds.  
 RHEL is a registered trademark of Red Hat, Inc. in the United States and other countries.  
 All other trademarks are the property of their respective owners.

### Manufactured By:

#### Alazar Technologies Inc.

6600 TRANS-CANADA HIGHWAY, SUITE 310  
POINTE-CLAIRE, QC, CANADA H9R 4S2

TOLL FREE: 1-877-7-ALAZAR  
TEL: (514) 426-4899 FAX: (514) 426-2723

E-MAIL: sales@alazartech.com

### DATASHEET REVISION HISTORY

#### Changes from version 1.3F (Nov 2021) to version 1.3G

	<b>Section, Page</b>
Changes to maintenance subscription inclusions: removed technical support	Software Development Kits, pg. 3
Added Windows 11	Support for Windows, pg. 3
Added new section to specify how AlazarTech handles technical support: Customers receive free technical support on hardware products that are under warranty. Out-of-warranty support requires the purchase of support hours.	Technical Support, pg. 4
Updated specification name from <i>Input protection</i> to <i>Absolute maximum input</i> Actual value did not change.	Acquisition System, pg. 5
Updated specification name from <i>Input protection</i> to <i>Absolute maximum input</i> Actual value did not change.	External Trigger (EXT) Input, pg. 6
Updated name for product <i>Software Development Kit</i> Now called: <i>ATS-SDK purchased with a digitizer board or ATS-GPU</i>	Ordering Information, pg. 6
Added products ATS-SDK-WOD and SUPPORT-HR5	Ordering Information, pg. 6

#### Changes from version 1.3E (Feb 2020) to version 1.3F

	<b>Section, Page</b>
Changed term for multi-board system to Leader/Follower	Multiple-Digitizer Synchronization, pg. 2
Updated support status for Windows 8.x and Windows Server versions 2012 R2, 2016, 2019	Support for Windows, pg. 3
Updated Linux Support (RHEL) and added new DKMS drivers	Linux Support, pg. 4
Added section: Extended Warranty	Extended Warranty, pg. 4

#### Changes from version 1.3D (Jan 2020) to version 1.3E

	<b>Section, Page</b>
Added note to advise that ATS310 is not recommended for new designs Suggested replacement is ATS9120	pg. 1
Updated suggested alternative product for dual-port memory from ATS460 to ATS9120	Overview, pg. 1
Added section to recommend ATS9120 PCIe digitizer card	Not Recommended for New Designs, pg. 1

#### Changes from version 1.3C (Jan 2019) to version 1.3D

	<b>Section, Page</b>
Changed <i>Sampling Rate</i> column to <i>Max. Sample Rate</i>	Feature Table, pg. 1
Removed qualified metrology lab as option for recalibrating ATS310	Calibration, pg. 3
Specified Windows 7 version support, re-ordered list of operating systems, and added end-of-support notice for Windows 7 and Windows Server 2008 R2	Support for Windows, pg. 3
Specified Linux distributions: CentOS, Debian, and Ubuntu	Linux Support, pg. 4

#### Changes from version 1.3B (Oct 2018) to version 1.3C

	<b>Section, Page</b>
Updated <i>Sanctions List</i> URL	Export Control Classification, pg. 4
Updated Trademark information	pg. 6

#### Changes from version 1.3A (Jan 2018) to version 1.3B

	<b>Section, Page</b>
Updated RoHS Compliance to RoHS 3	Global change
Clarified Operating System Support	Feature Table, pg. 1
Corrected trigger engines: changed to J and K (instead of X and Y)	Triggering, pg. 2
Removed oscilloscope calibrator model	Calibration, pg. 3
Added information on ATS-SDK license	Software Development Kits, pg. 3
Added list of supported Microsoft Windows versions	Support for Windows, pg. 3
Added missing $\pm 20$ V input range for 1 M $\Omega$ input impedance	Acquisition System, pg. 5
Corrected Internal Clock Accuracy to $\pm 100$ ppm	Timebase System, pg. 5
Corrected Trigger Engine Combination and Trigger level accuracy	Triggering System, pg. 6
Added <i>Optional Trigger Output</i> section	Optional Trigger Output, pg. 6
Added subscription length for ATS-SDK	Ordering Information, pg. 6
Added Trademark information	pg. 6

### DATASHEET REVISION HISTORY

#### Changes from version 1.3 (Sept 2017) to version 1.3A

#### Section, Page

Added CNRC as calibration standard	Calibration, pg. 3
Corrected size of card	Physical, pg. 5
Updated email address	Manufactured By, pg. 6

#### Changes from version 1.2E (Jan 2013) to version 1.3

#### Section, Page

Added Python to list of SDK supported languages, and Support for Windows & Linux	Features, pg. 1
Changed maximum number of channels for multi-channel data acquisition systems to 8	Overview, pg. 1
Removed note on availability of special order item for higher channel counts	Overview, pg. 1
Added Python & LabVIEW to list of supported languages for ATS-SDK, removed ATS-VI	Overview, pg. 1
Corrected maximum number of channels, 8 board synchronization deprecated	Multiple-Digitizer Synchronization, pg. 2
Added list of available SyncBoards	Multiple-Digitizer Synchronization, pg. 2
Updated section on RoHS compliance	RoHS Compliance, pg. 3
Modified AlazarDSO description	AlazarDSO Software, pg. 3
Removed section <i>AlazarDSO Plug-Ins</i> ; product deprecated	AlazarDSO Plug-Ins, pg. 3
New section <i>Software Development Kits</i> to replace sections: <i>ATS-SDK Software Development Kit</i> and <i>ATS-VI Software Development Kit</i>	Software Development Kits, pg. 3
Replaced section <i>ATS-Linux</i> with new <i>Linux Support</i> section	Linux Support, pg. 3
Added Export Control Classification information	Export Control Classification, pg. 3
Added section on EC Conformity	EC Conformity, pg. 4
Added section on FCC & ICES-003 Compliance	FCC & ICES-003 Compliance, pg. 4
Updated External Trigger Input Impedance to 1 MΩ ±10%	External Trigger Input, pg. 6
Updated list of Materials Supplied	Materials Supplied, pg. 6
Updated list of Certification and Compliances	Certification and Compliances, pg. 6
Corrected product names for ATS310-006, ATS310-007	Ordering Information, pg. 6
Added products ATS310-061, ATS310-062	Ordering Information, pg. 6
Updated ATS-SDK and ATS310-005 product names	Ordering Information, pg. 6
Removed product ATS-VI (ATS-SDK now supports LabVIEW)	Ordering Information, pg. 6
Removed products ATS310-008, ATS310-Linux, ATS-STR, ATS-DSO-PDK	Ordering Information, pg. 6